

B031, Rev. -

1. Finish Goods PKG photo

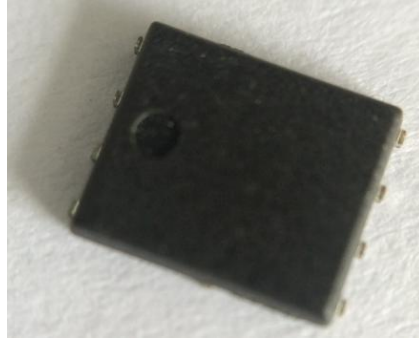

2. Packing method

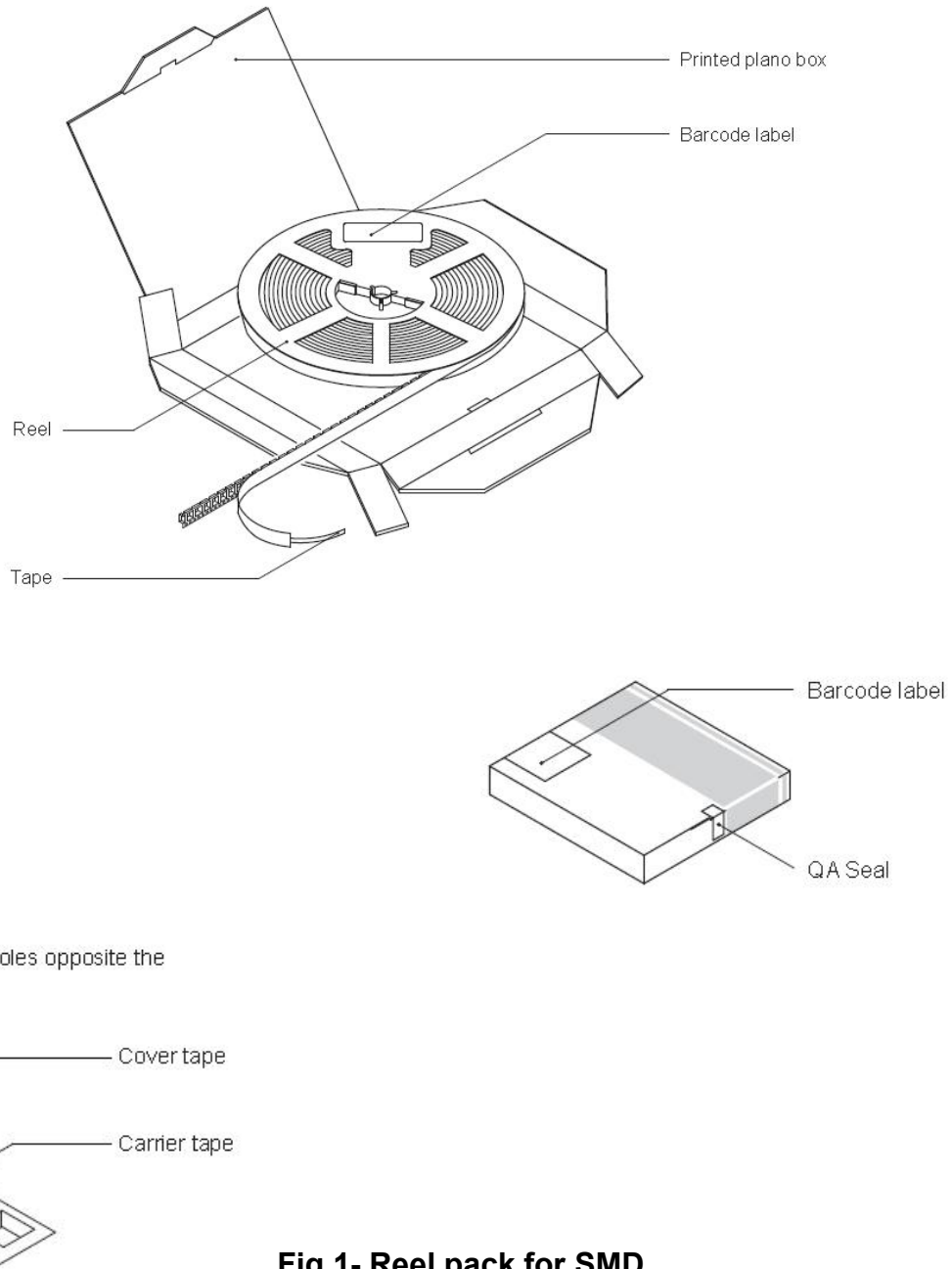

Fig.1- Reel pack for SMD

Table 1. Packing information

Package version	Reel dimensions $\phi \times H$ (mm)	Per Reel (pcs)	Reel Weight (Kg)	Reels per box	Inner box dimensions L×W×H (mm)	Inner box weight (Kg)	Outer box weight (Kg)
DFNWB5×6-8L	$\Phi 330 \times 17.6$	3000	0.79	2	335×335×45	1.73	15

3. Product orientation

Standard product orientation DFNWB5×6-8L

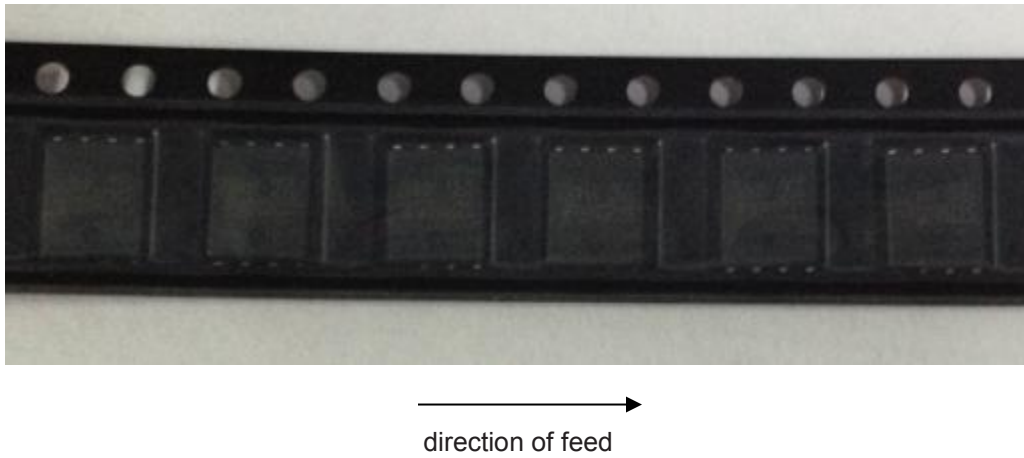

Fig 2. Product orientation in carrier tape

4. Carrier tape dimensions (In mm)

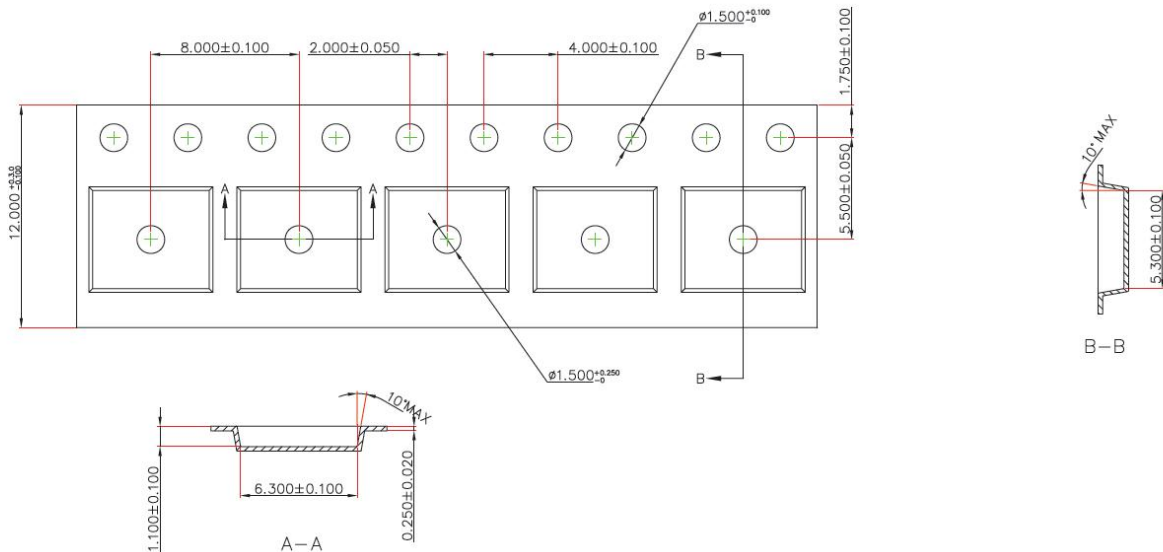

Fig 3. Carrier tape dimensions

B031, Rev. -

5. Reel dimensions (In mm)

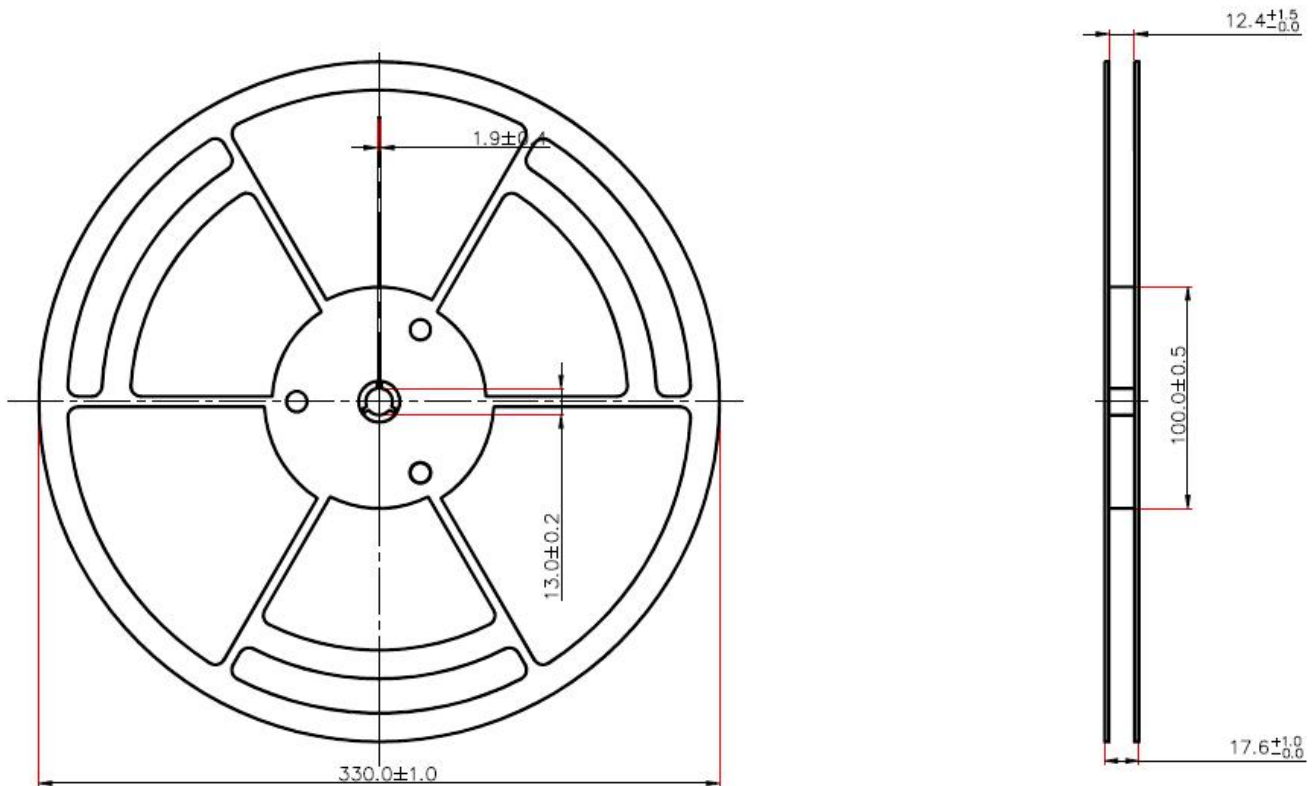

Fig 4. Reel dimensions